

BINOTTO MFC - CYLINDERS

Binotto®

THE TIPPING POWER

TYPE :

TIPPING WEIGHT¹ :

MFC 145-4-5100 - D₁ 267

26 - 38 Tons

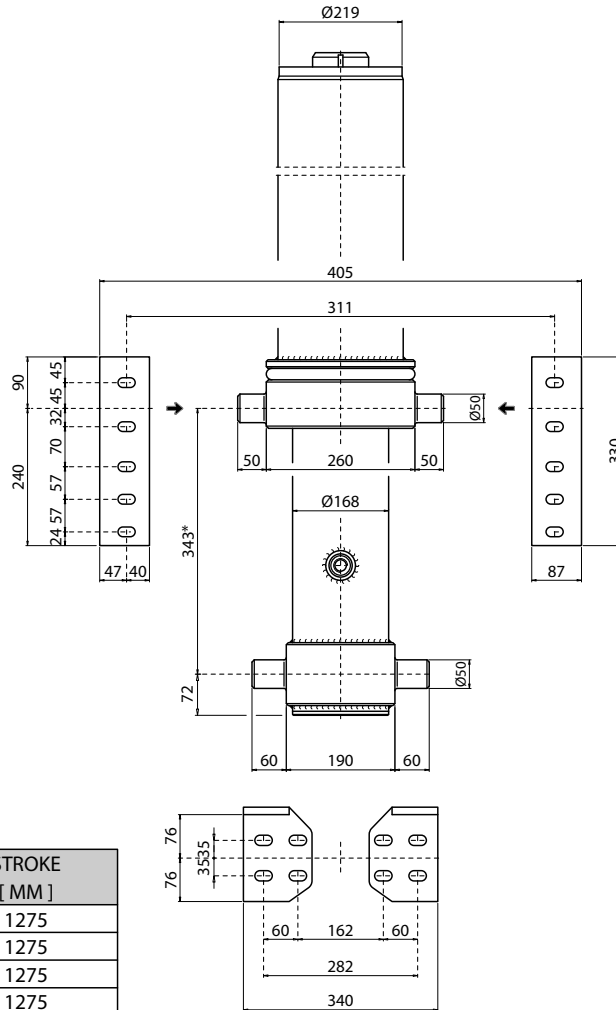
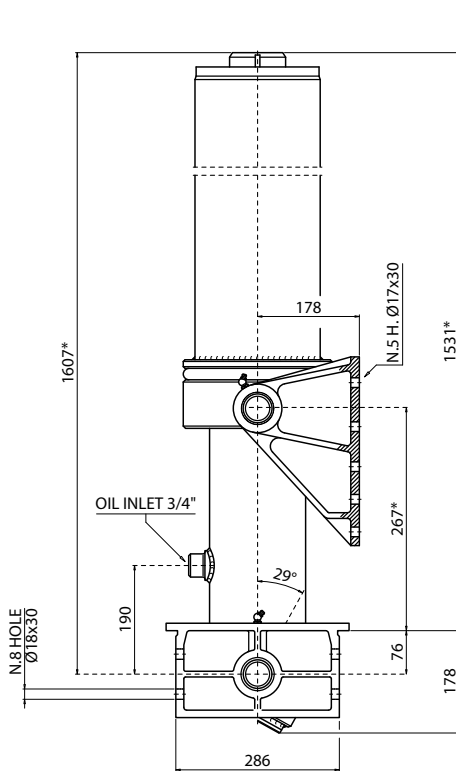

STAGES [N]	EFF. DIAMETER [MM]	THRUST AT 200 BAR [TON]	STROKE [MM]
I	Ø 145	33.0	1275
II	Ø 126	24.9	1275
III	Ø 107	18.0	1275
IV	Ø 088	12.2	1275
V			
VI			

SPECIFICATION :

Type cylinder : MFC 145-4-5100 - D₁ 267
 Stages number : 04
 Stroke : 5100 mm
 Weight cylinder only : 271 Kgs.
 Weight including brackets : 313 Kgs.
 Working volume : 056 Ltrs.
 Max. working pressure : 200 bar
 Oil : see oil specification sheet

¹ : Tipping weight = net weight body + payload.
 Fitted centres (*) = closed centres plus 20mm pull out.

REMARKS :

BRACKETS KIT (NOT INCLUDED)

CODE	DESCRIPTION	Q.TY
SIL#MDC	Lower bracket - pin Ø 50 / 286	02
SSL#PGC	Upper bracket R - pin Ø 50 / 178	01
SSL#PHC	Upper bracket L - pin Ø 50 / 178	01

BRACKETS MOUNTING KIT (NOT INCLUDED)

CODE	DESCRIPTION
KFSI#001	Lower brackets mounting kit (16 - M16 x 1.5 x 50 mm)
KFSS#002	Upper brackets mounting kit (10 - M16 x 1.5 x 60 mm)