

BINOTTO MFC - CYLINDERS

Binotto®

THE TIPPING POWER

TYPE :

TIPPING WEIGHT¹ :

MFC 165-5-7050 - D, 267

38 - 42 Tons

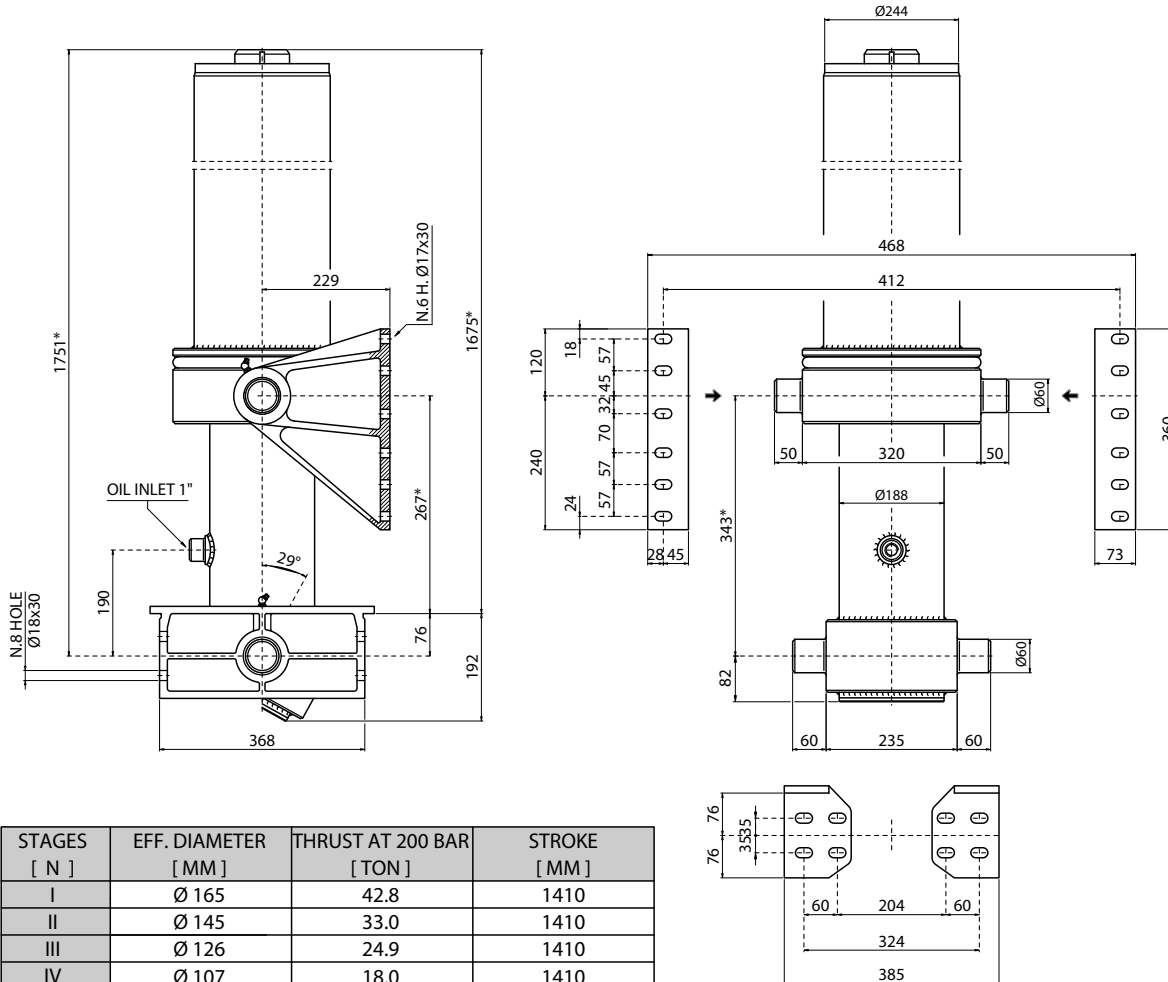

STAGES [N]	EFF. DIAMETER [MM]	THRUST AT 200 BAR [TON]	STROKE [MM]
I	Ø 165	42.8	1410
II	Ø 145	33.0	1410
III	Ø 126	24.9	1410
IV	Ø 107	18.0	1410
V	Ø 088	12.2	1410
VI			

SPECIFICATION :

Type cylinder : MFC 165-5-7050 - D, 267
 Stages number : 05
 Stroke : 7050 mm
 Weight cylinder only : 386 Kgs.
 Weight including brackets : 440 Kgs.
 Working volume : 092 Ltrs.
 Max. working pressure : 200 bar
 Oil : see oil specification sheet

¹ : Tipping weight = net weight body + payload.
 Fitted centres (*) = closed centres plus 20mm pull out.

REMARKS :

BRACKETS KIT (NOT INCLUDED)

CODE	DESCRIPTION	Q.TY
SIL#MIC	Lower bracket - pin Ø 60 / 368	02
SSL#PMC	Upper bracket R - pin Ø 60 / 229	01
SSL#PNC	Upper bracket L - pin Ø 60 / 229	01

BRACKETS MOUNTING KIT (NOT INCLUDED)

CODE	DESCRIPTION
KFSI#001	Lower brackets mounting kit (16 - M16 x 1.5 x 50 mm)
KFSS#003	Upper brackets mounting kit (12 - M16 x 1.5 x 60 mm)