

# BINOTTO MFC - CYLINDERS

## Binotto®

THE TIPPING POWER

TYPE :

TIPPING WEIGHT<sup>1</sup> :

MFC 165-5-8050 - D, 267

36 - 39 Tons

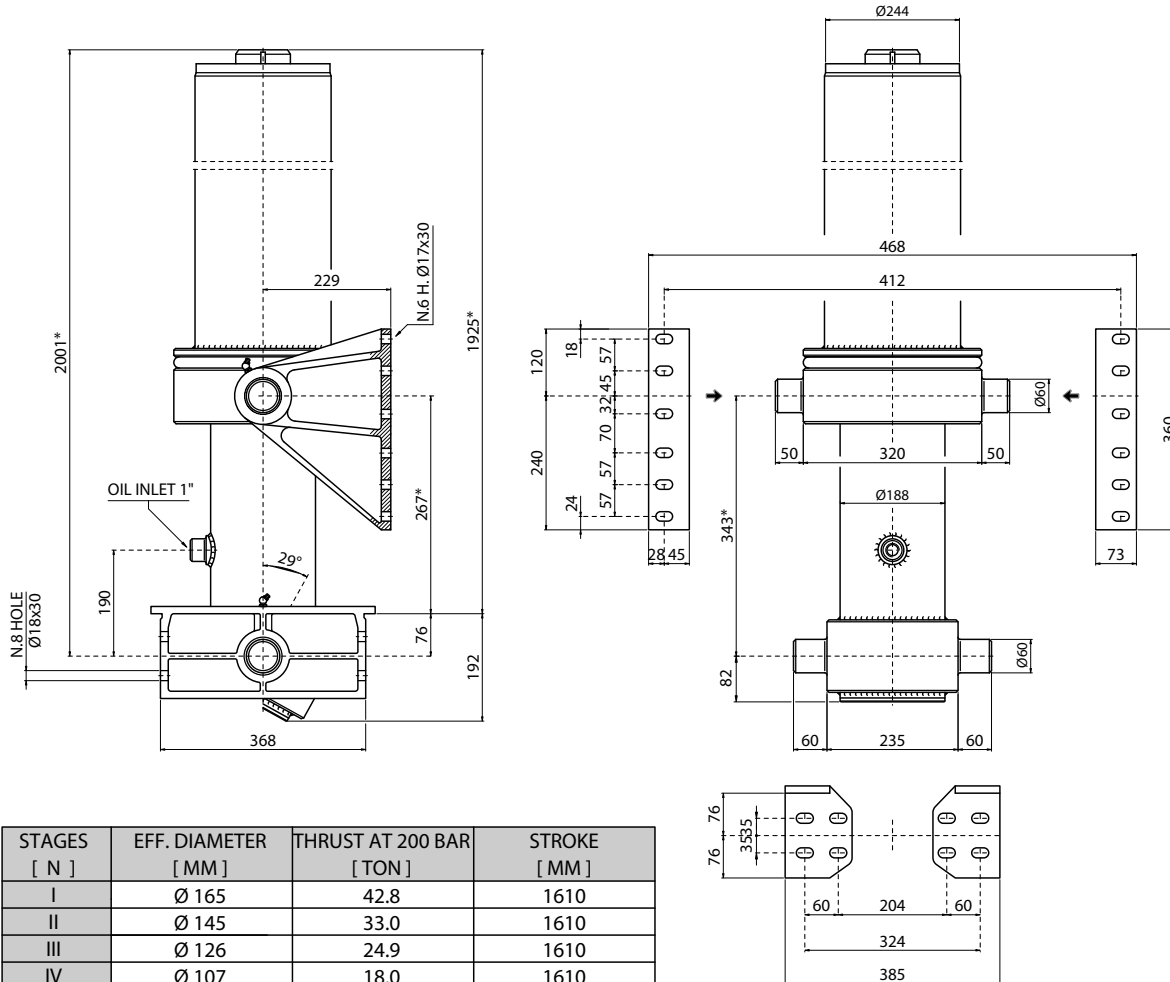

STAGES [ N ]	EFF. DIAMETER [ MM ]	THRUST AT 200 BAR [ TON ]	STROKE [ MM ]
I	Ø 165	42.8	1610
II	Ø 145	33.0	1610
III	Ø 126	24.9	1610
IV	Ø 107	18.0	1610
V	Ø 088	12.2	1610
VI			

### SPECIFICATION :

Type cylinder : MFC 165-5-8050 - D, 267  
 Stages number : 05  
 Stroke : 8050 mm  
 Weight cylinder only : 432 Kgs.  
 Weight including brackets : 486 Kgs.  
 Working volume : 105 Ltrs.  
 Max. working pressure : 200 bar  
 Oil : see oil specification sheet

<sup>1</sup> : Tipping weight = net weight body + payload.  
 Fitted centres ( \* ) = closed centres plus 20mm pull out.

### REMARKS :

#### BRACKETS KIT ( NOT INCLUDED )

CODE	DESCRIPTION	Q.TY
SIL#MIC	Lower bracket - pin Ø 60 / 368	02
SSL#PMC	Upper bracket R - pin Ø 60 / 229	01
SSL#PNC	Upper bracket L - pin Ø 60 / 229	01

#### BRACKETS MOUNTING KIT ( NOT INCLUDED )

CODE	DESCRIPTION
KFSI#001	Lower brackets mounting kit ( 16 - M16 x 1.5 x 50 mm )
KFSS#003	Upper brackets mounting kit ( 12 - M16 x 1.5 x 60 mm )